

# 4K

THE BEST  
125 kVA  
GENSET

**KOEL**  
**GREEN**



BY  
KIRLOSKAR

---

**EFFICIENCY. INTEGRATED**



20% cash-back  
every 1000 hours

4K



# Most fuel efficient 125 kVA genset

## An engineering master-stroke



While delivering full 125 kVA power, **4K** saves over **2 litres** diesel for every hour run.

This means a whopping **Rs. 1,20,000** saving per 1000 hours. Contribution to India's forex saving and green cause is extra!

Low maintenance cost



4K

▶ One smart decision & lifetime of savings  
Enjoy the benefits of low Opex



For delivering 125 kVA power, **4K** consumes **10% lower lube oil.**

This, combined with affordable consumables and spares parts makes **4K** the most economical 125 kVA Genset to operate and maintain.

A muscular man is shown from the waist up, lifting a glowing, fiery barbell. The barbell is composed of several circular weights that are emitting a bright orange and yellow light, with flames and sparks rising from the base. The man's muscles are highly defined and appear to be glowing with the same fiery energy. The background is dark, with some sparks floating in the air.

Superior strength

4K



# Superior block-loading capacity

For demanding applications



**4K** engine is capable of **55%** block loading, offering superior strength to handle step-loads/ block-loads. As such, **4K** ensures smooth & dependable power transfer even starting large motors.

# Pushing technology limits

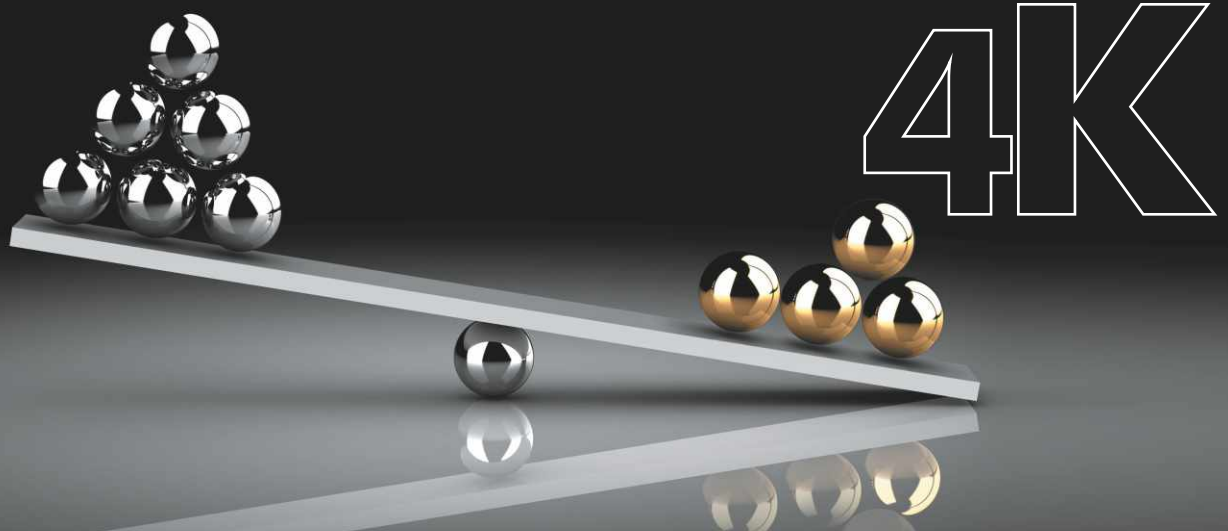



# Cutting edge engine technology

4 are better than 6



**4K** with 4 cylinders engine generates **156 BHP** same as that generated by 6-cylinder engines of other makes. This technology feat enables multiple user benefits, while giving same 125 kVA power output.

Compact foot print



4K



# Big performance in small package

Compact design with high performance



**4K** Generator exploits 4-cylinder engine configuration to offer compact Generator dimensions.

With over **10% saving** in space, it offers relief to space-conscious installations and users.

Widest service coverage

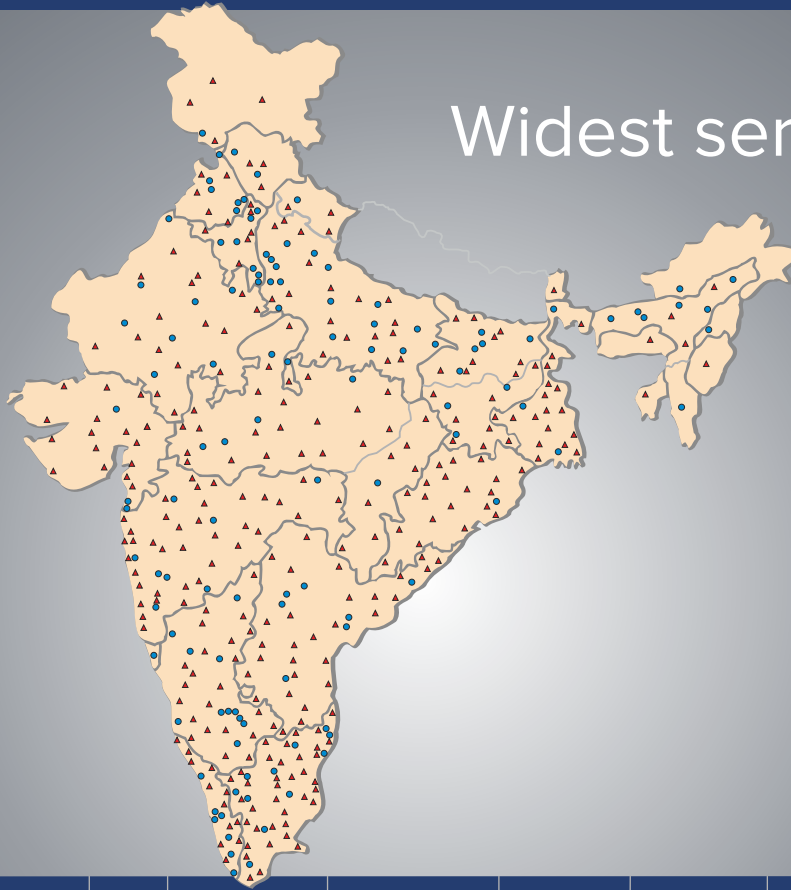

4K

Any where in India, you are just a step away  
... and we are just a call away



**4K** Genset is supported by widest network of 450 + service touch-points and 6000+ trained service engineers.

One call to [+91 8806334433](tel:+918806334433) and product support is available at the doorstep.

# Technical specifications

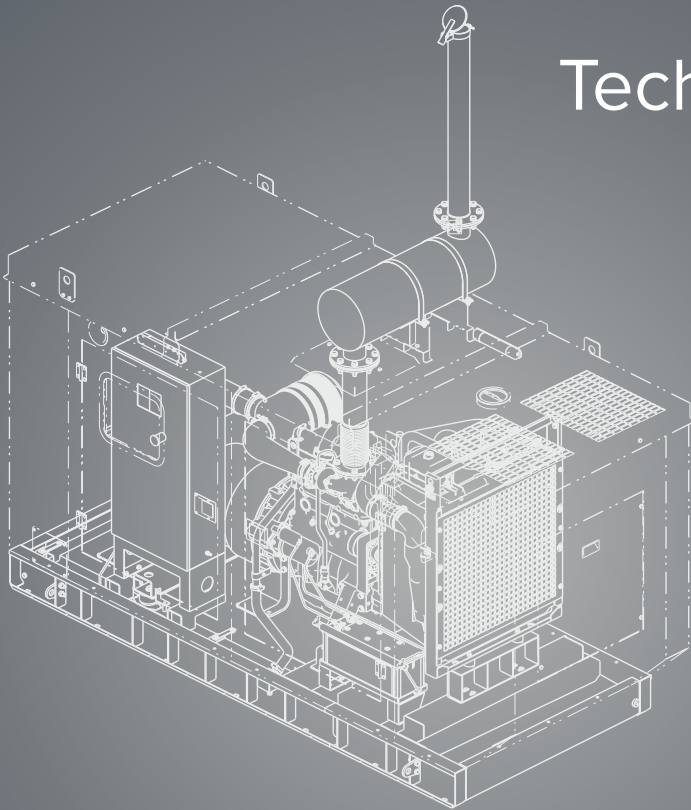

# 4K

Prime Rating at rated rpm (as per ISO8528) <sup>1</sup>	kVA	125	
	kW	100	
Genset Model		KG1-125WS	
Frequency	Hz	50	
Power factor	lagging	0.8	
Voltage	V	415 3Ø	
Governing class (As per ISO 8528 Part-V)		G3	
Noise level	dBA	< 75	
Fuel Consumption*	At 100 % Load	27.4	
	At 75 % Load	20.2	
	At 50 % Load	15.3	
Fuel tank capacity	Ltrs	230	
°Weight of genset with canopy (approx.) <sup>^</sup>	Dry	Kg	2090
	Wet	Kg	2290
Overall dimensions of genset <sup>^</sup>	Length	mm	3200
	Width	mm	1300
	Height	mm	1795
Electrical Battery starting voltage	Volts-DC	12	
<b>ENGINE</b>			
Engine Model		4K1080TA G2	
Rated output (Prime Continuous rating as per ISO 8528-1)	kW	114.7	
	HP	156	
No. of cylinder	Number	4	
Cubic capacity <sup>2</sup>	Ltrs	4.32	
Bore x Stroke	mm	105 x 125	
Rated Speed	RPM	1500	
Aspiration	NA/T/C/TA	TA	
Lube Oil change period	hrs.	500	
Lube oil Sump Capacity	Ltrs	14	
Coolant Capacity	Ltrs	21	
<b>ALTERNATOR</b>			
Insulation Class		Class H	
Alternator Efficiency (at 100% load) 0.8 pf**	%	92.5	
Max Voltage Dip at Full Load 0.8 pf Lag	sec	≤ 20 %	
Max Time to build up rated voltage at Rated RPM		Voltage recovery time 6 sec	



BY  
KIRLOSKAR  
**EFFICIENCY. INTEGRATED**

#### Notes

<sup>^</sup> Tolerances Apply

\*With 0.845 Specific Gravity of diesel ( 5 %

<sup>o</sup> These weight are for handling & transportation only

\*\* Efficiency of Alternator as per standards IS 4722 and IEC 34-1

For Site Conditions other than standard operating conditions consult KOEL for available prime power.

For intermediate ratings, kindly contact nearest KOEL office

## EFFICIENCY. INTEGRATED

**EFFICIENT  
PRODUCTS**



**EFFICIENT  
SERVICE**



**EFFICIENT  
DELIVERIES**



**EFFICIENT  
SOLUTIONS**



**EFFICIENT  
NETWORK**



**EFFICIENT  
24X7 CARE**



## KIRLOSKAR OIL ENGINES LIMITED

Laxmanrao Kirloskar Road, Khadki,  
Pune 411 003 INDIA.

[www.koelgreen.com](http://www.koelgreen.com)



**8806334433**

**1800 233 3344**

[koel.helpdesk@kirloskar.com](mailto:koel.helpdesk@kirloskar.com)